

## STEREOMETRIC PROJECTION OF 3D AND 4D OBJECTS IN CURVILINEAR PROJECTIVE SPACE

*UDC 515.173:535.317.24*

**Risto Tashevski, Vladimir Dukovski**

Faculty of Mechanical Engineering  
The "Sts. Cyril and Methodius" University  
P.O. Box 464, 1000 Skopje, Macedonia  
E-mail: risto@mf.ukim.edu.mk

**Abstract.** *In this paper a mathematical model and a computer program for stereometric projection of 3D and 4D objects in curvilinear (hyperboloid and paraboloid) projective spaces are presented. The aim of this projection is a realistic presentation of objects in the human surrounding. This means that the presented objects should not be different from the real ones. In reality the objects are projected on the retina of the eye mechanism. The retina does not have a regular geometric shape. The shape of the retina could be approximated with a hyperboloid or paraboloid surface. The way to the realistic visual presentation of objects is the stereometrical projection in the curvilinear projective space. Stereometrically projected objects in various projective spaces presented on two-dimensional plane (paper, monitor) are received by optical apparatus (stereoscope, glasses).*

**Key words:** *Stereometry (Stereo Geometry), Curvilinear (Hyperboloid, Paraboloid) Projective Space, 3D And 4D Objects*

### 1. INTRODUCTION

The virtual reality today is the most current and the most fashionable theme in which various scientific fields have been involved. Virtual reality means visualization of a certain space in which there is a possibility for interactive action. This space should produce the feeling that the visualization is real, that he/she is placed in a real world in which he/she could actively participate. In order to achieve this, all the sense components should be simulated - sight, hearing, touch, taste, feelings (psychological moments) and reactions of the other subjects and objects in that space. Stereometric projection is used for sight simulation, as a visual component of the virtual reality. The stereometric projection begins from two centers on a vertical plane or surface, through which two projections are

received (Geiger *et al*, 1995). When these projections are viewed through an optical equipment they create a three-dimensional picture in the viewer's eyes.

In the human eye mechanism, which consists of two eyes, objects are presented as independent projections on the retina of each eye. The two projections are connected into three-dimensional image in the human brain. The eye retina does not have regular geometric shape and can be closely described as ellipsoid, hyperboloid or paraboloid (Rozenfeld, 1969). The use of curvilinear projective space for a realistic presentation of objects is justified with the form of the retina projective space.

This article deals with the projection of objects on hyperboloid and paraboloid projective spaces, as a close approximation of the retina projective space.

## 2. STEREO-METRIC PROJECTION IN A HYPERBOLOID PROJECTIVE SPACE

Stereometric projection in a hyperboloid projective space means projecting from two centers  $O_L(O'_L, O''_L)$  and  $O_R(O'_R, O''_R)$  (Figure 1) on a hyperboloid surface. The cube is projected on a hyperboloid surface with radius  $R$  (of velar circle) from two centers which are placed on a basic circle, with radius  $r$  or a diameter equivalent to the eye distance 65-70 mm (Shotikov and Mihno, 1972). The applied methodology is explained in Figure 2. Projective rays are drawn from the point  $A(A', A'')$  (of the cube), in a way they can tangent the basic circle in the points  $O_1(O'_1, O''_1)$  and  $O_2(O'_2, O''_2)$  (eye points). The stereometric projections of the point  $A(A', A'')$  are formed at the place where projective rays stab the hyperboloid,  $(A'_L, A'_R)$  above the horizontal projective plane (first projection). The second stereometric projections of the point  $A, A''_L$  and  $A''_R$  can be found on the ordinate of the first projections of the points and on the second projections of the projective rays. The  $z$  coordinate of the second projection can be defined with introduction of the auxiliary axis  $x^1_4$ .

A hyperboloid coordinate system  $Ox_1y_1$  is introduced in order to present the received stereometric projections on a paper or computer screen. Axis  $x_1$  follows circle and  $y_1$  hyperbola. The other notations are:

- $R$  – radius of velar circle
- $r$  – radius of the basic circle
- $x_{[i]}, y_{[i]}, z_{[i]}$  – coordinates of the real object
- $l = \overline{O_1A}$  – distance from the eye point  $O_1$  to the vertex  $A$
- $l_i = \overline{C'A}$  – distance from the center of the hyperboloid to the vertex  $A$
- $d$  – main distance
- $a, b$  – hyperboloid axis

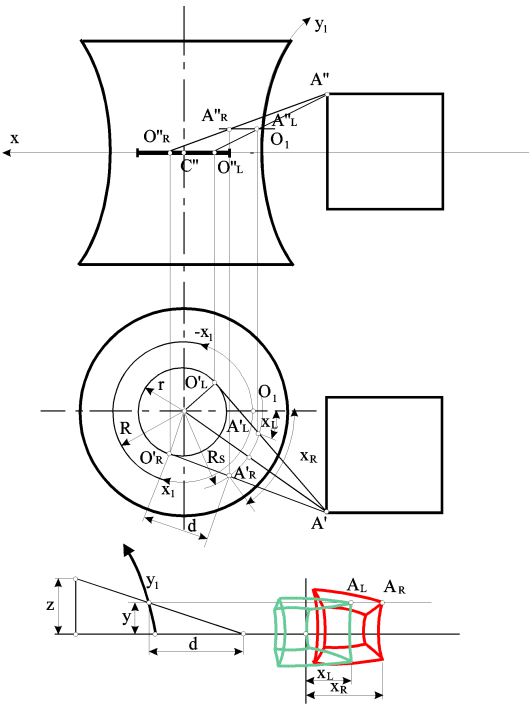

Fig. 1. Method for developing stereometric projections of a cube in a hyperboloid space

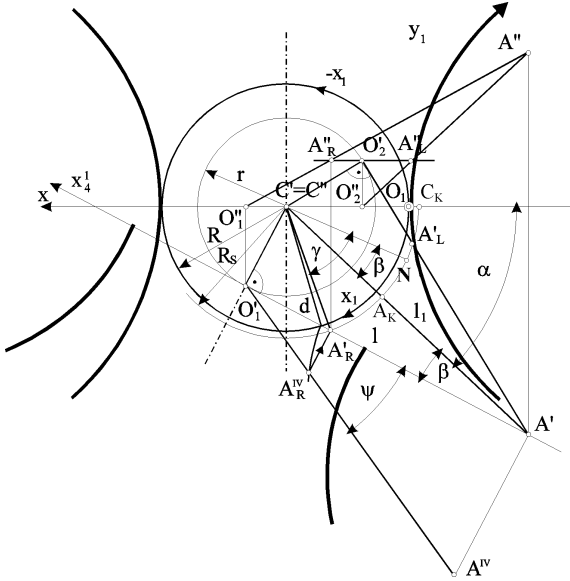

Fig. 2. Graphical representation of the mathematical model for stereometric projections in a hyperboloid projective space

The auxiliary point  $N$  is introduced for finding the coordinates ( $x_L$  and  $x_R$ ) of the stereometric points  $A_L$  and  $A_R$ . Summing the distances (lengths of the circled vault) from point  $N$  we get (Fig. 2):

$$x_{[i]R} = \overline{A_K C_K} - \overline{A_K N} + \overline{N A_R'} \quad (1)$$

If the distances (the lengths of the circled vaults) are computed using the given angles  $\alpha$ ,  $\beta$ ,  $\gamma$  and the radius  $R_s$ , we get:

$$x_{[i]R} = R_s \alpha - R_s \beta + R_s \gamma \quad (2)$$

With the introduction of coordinates  $x_{[i]}$ ,  $y_{[i]}$ ,  $z_{[i]}$  and the parameter  $r$ , we get:

$$x_{[i]R} = R_s \arcsin \frac{y_{[i]}}{\sqrt{x_{[i]}^2 + y_{[i]}^2}} - R_s \arcsin \frac{r}{\sqrt{x_{[i]}^2 + y_{[i]}^2}} + R_s \arcsin \frac{r}{R_s} \quad (3)$$

Using analogy we get:

$$x_{[i]L} = R_s \arcsin \frac{y_{[i]}}{\sqrt{x_{[i]}^2 + y_{[i]}^2}} + R_s \arcsin \frac{r}{\sqrt{x_{[i]}^2 + y_{[i]}^2}} - R_s \arcsin \frac{r}{R_s} \quad (4)$$

The relationship between the *shortened radius*  $R_s$  and the radius of the hyperboloid surface  $R$  is:

$$R_s = \sqrt{d^2 + r^2} \quad (5)$$

where  $d = \frac{lb\sqrt{R^2 - r^2}}{\sqrt{l^2 b^2 - z_{[i]}^2}}$  and  $l = \sqrt{x_{[i]}^2 + y_{[i]}^2 - r^2}$

Fourth projection ( $A^{IV}$ ) defines the coordinates  $y_L$  and  $y_R$ , which are equal to the length of the hyperbolic vault in the limits from the point  $(a, 0)$  to the point  $(x, z)$  expressed with the integral:

$$y_{[i]R} = y_{[i]L} = \int_a^x \sqrt{\frac{(a^2 + b^2)x_{[i]}^2 - a^4}{a^2(x_{[i]}^2 - a^2)}} dx_{[i]} \quad (6)$$

The value of the eccentricity  $e$  can be computed with the relation  $a^2 + b^2 = a^2 e^2$ . The integral (6) can be expressed further in parametric form in the limits from 0 to  $\psi$ :

$$y_{[i]R} = y_{[i]L} = ae \int_0^\psi \sqrt{1 - \frac{\cos^2 t}{e^2}} \frac{dt}{\cos^2 t} \quad (7)$$

where  $a = \sqrt{R^2 - r^2}$

The bynom  $\left(1 - \frac{\cos^2 t}{e^2}\right)^{\frac{1}{2}}$  can be substituted by the bynom row:

$$\left(1 - \frac{\cos^2 t}{e^2}\right)^{\frac{1}{2}} = 1 - \frac{1}{2} \frac{\cos^2 t}{e^2} - \frac{1}{2 \cdot 4} \frac{\cos^4 t}{e^4} - \frac{1 \cdot 3}{2 \cdot 4 \cdot 6} \frac{\cos^6 t}{e^6} - \dots - \frac{1 \cdot 3 \cdot 5 \dots (2n-3)}{2 \cdot 4 \cdot 6 \dots 2n} \frac{\cos^{2n} t}{e^{2n}} - \dots$$

The number of considered members of the bynom row depends on the expected accuracy. Each member of the row is integrated in the limits from 0 to  $\psi$ .

With the stereometric projections available, it is easy to get the coordinates of the points of the real object by using the reverse procedure (Lengagne *et al*, 1996):

$$x_{[i]} = l_1 \cos \alpha; \quad y_{[i]} = l_1 \sin \alpha; \quad z_{[i]} = l \tan \psi; \quad (8)$$

$$\text{angles } \alpha = \frac{x_{[i]R} + x_{[i]L}}{2R_s}; \quad \psi \approx \frac{y_{[i]R}}{\sqrt{R^2 - r^2}};$$

With the application of the mathematical expressions (3), (4) and (7) an algorithm has been created for development of stereometric projections of 3D and 4D objects in a hyperboloid space.

### 3. STEREOMETRIC PROJECTION IN A PARABOLOID PROJECTIVE SPACE

The procedure for stereometric projection in a paraboloid projective space (Figure 3) follows the same pattern as the case of hyperboloid projective space. Figure 4 explains the mathematical model. New notations are:

- $R$  – radius of a paraboloid surface
- $l_1 = \overline{C'A'}$  – distance from the center of the paraboloid to the vertex  $A$
- $p$  – distance from directress to the focus of the paraboloid

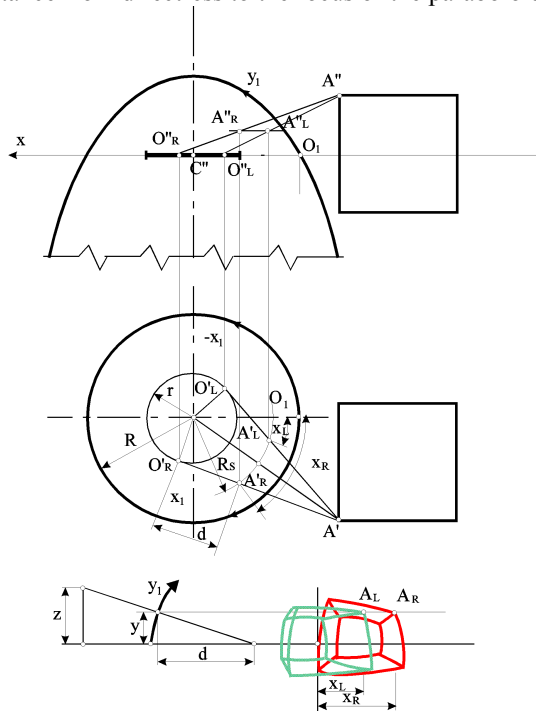

Fig. 3. Method for developing stereometric projection of a cube in a paraboloid projective space

Relations (1), (2), (3) and (4) can be used also in a case of paraboloid projective space. In this case values for  $d$  and  $l$  in relation (5) are:

$$d = \frac{\sqrt{R^2 - r^2} (z_{[i]} \pm \sqrt{z_{[i]}^2 + l^2})}{l}, \quad l = \sqrt{x_{[i]}^2 + y_{[i]}^2 - r^2}$$

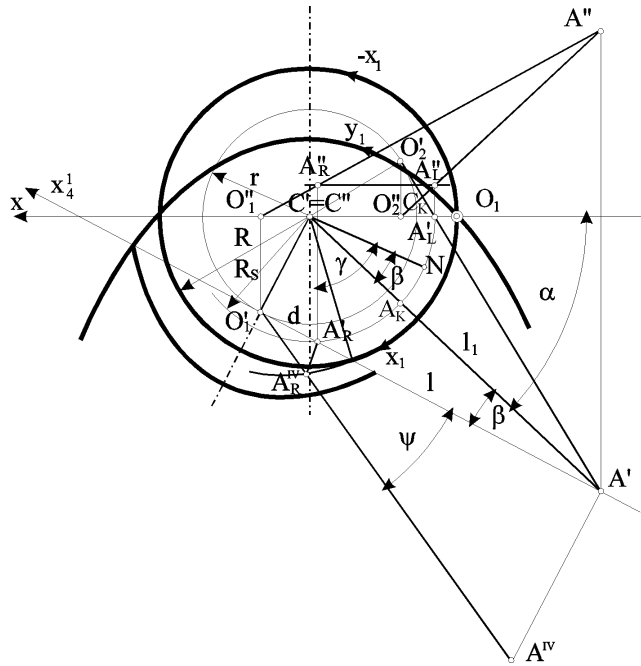

Fig. 4. Graphical representation of the mathematical model for stereometric projection in a paraboloid projective space

Using the fourth projection we can define the coordinates  $y_L$  and  $y_R$ , which are equivalent to the length of the parabolic vault in the interval  $(0,0)$  and  $(x,z)$ , that can be expressed with an integral:

$$y_{[i]R} = y_{[i]L} = \frac{1}{p} \int_0^z \sqrt{p^2 + z_{[i]}^2} dz_{[i]} \tag{10}$$

With the introduction of  $u = \sqrt{p^2 + z_{[i]}^2}$ ,  $dv = dz_{[i]}$ , and partial integration, we get:

$$y_{[i]R} = y_{[i]L} = z_{[i]} \sqrt{p^2 + z_{[i]}^2} - \int_0^z \sqrt{p^2 + z_{[i]}^2} dz_{[i]} + p^2 \log \frac{z_{[i]} + \sqrt{p^2 + z_{[i]}^2}}{p}$$

and further:

$$y_{[i]R} = y_{[i]L} = \frac{z_{[i]}}{2p} \sqrt{p^2 + z_{[i]}^2} + \frac{p}{2} \operatorname{arsh} \frac{z_{[i]}}{p} \tag{11}$$

where  $p = \sqrt{R^2 - r^2}$ .

The coordinates of the vertexes of the real objects can be calculated using relations (8).

With the use of expressions (3), (4) and (11) an algorithm for stereometric projections of 3D and 4D objects in paraboloid projective space has been developed.

#### 4. COMPUTER PROGRAM AND EXAMPLES

Based on the presented methodology a computer program for development of stereometric projections in curvilinear projective space has been developed (Figure 5). Some examples of the use of this computer program are presented in the figures 6,7,8,9,10,11,12 and 13.

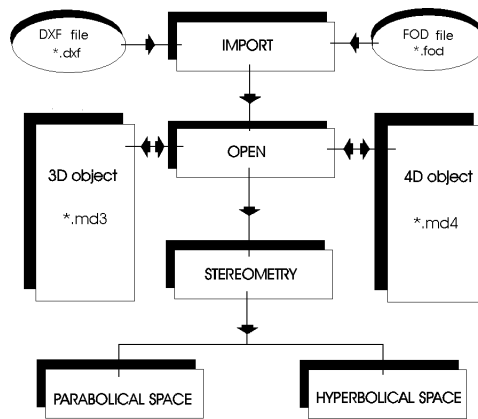

Fig. 5. Block diagram of algorithm for developing of stereometric projections in a hyperboloid and paraboloid projective space

The characteristic feature of the stereometric projection on a hyperboloid and paraboloid surface is that all the edges of the projections are curved lines. The curved lines appear as a result of the round and hyperbolic extracts of the hyperboloid, and of the round and parabolic extracts of the paraboloid (Figure 6,7,8,9).

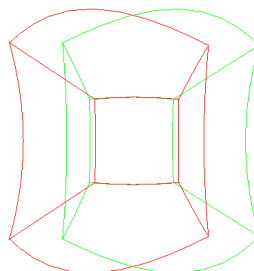

Fig. 6. Stereometric projections of a cube in a hyperboloid projective space

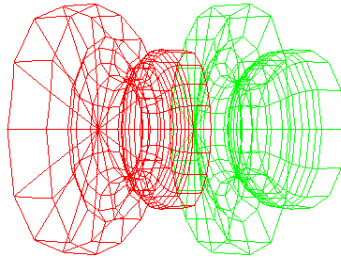

Fig. 7. Stereometric projections of 3D object in a hyperboloid projective space

In case of stereometric projection of 4D objects, they are transformed first in 3D objects and then through their vertexes the projective rays of the two eye points are drawn (Banchoff, 1978) (Hoffmann and Zhou, 1991).

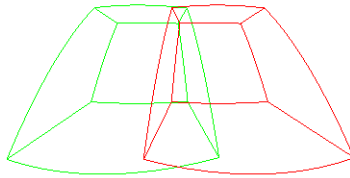

Fig. 8. Stereometric projections of a cube in a paraboloid projective space

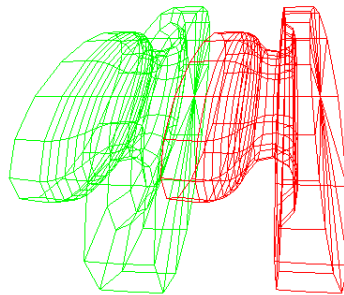

Fig. 9. Sterometric projections of 3D object in a paraboloid projective space

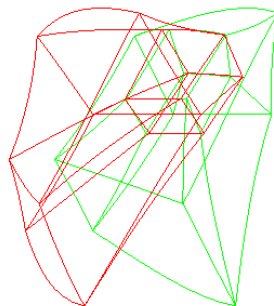

Fig. 10. Stereometric projections of 4D cube in a hyperboloid projective space



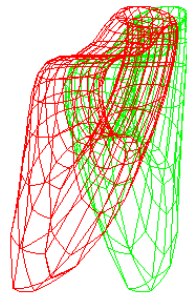

Fig. 11. Stereometric projections of 4D surface in a hyperboloid projective space  
 $f(x,y,z,w) = \{\cos(x), \sin(x), \cos(y)\sqrt{y^2}, \sin(y)\}$

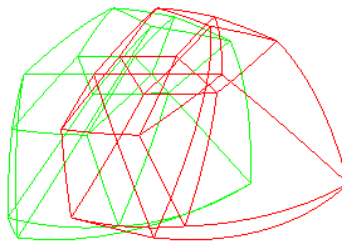

Fig. 12. Stereometric projections of 4D cube in a paraboloid projective space.



Fig. 13. Stereometric projections of 4D surfaces in a paraboloid projective space  
 $f(x,y,z,w) = \{\sin(x)\cos(x), \cos(y), y\sin(x), \sin(x)\cos y\}$

## 6. CONCLUSION

The stereometric projection in a curvilinear projective space is far more realistic than the stereometric projection on a plane. Algorithms and computer program for projecting of 3D and 4D objects on a hyperboloid and paraboloid space were presented. Some examples of the use of the computer program were presented also. Further development of the realistic presentation of objects should firmly take into consideration the projective space of the objects.

## REFERENCES

1. Banchoff, F. T.: *Real Time Computer Graphics Analysis of Figures in Four-Dimensional Space*, Computer - Aided Design, Vol. 10, No. 1, pp. 45-47., 1978.
2. Hoffmann, M. C. and Zhou J.: *Some Techniques for Visualizing Surfaces in Four-Dimensional Space*, Computer - Aided Design, Vol. 23, No. 2, pp. 83-91, 1991
3. Lengagne, R., Fua, P., and Monga, O.: *Using Crest Lines to guide Surface Reconstruction from Stereo*, Proceedings of the 13th International Conference on Pattern Recognition, Vienna, Austria, pp. 218-223, 1996.
4. Rozenfeld, B. A.: *Non-Euclid Spaces*, Nauka - Publishing Co., Moscow, Russia, 1969.
5. Shotikow, A. V. and Mihno, O. D.: *Stereo - Panoramic Picture and Methods of Construction*, Scientific papers MIISP, Moscow, Russia, Vol. 9, No. 7, pp. 150-157, 1972.
6. Geiger, D., Ladendorf, B., and Yuille, A.: *Occlusions and Binocular Stereo*, International Journal of Computer Vision, No.14, pp.211-226, 1995.
7. R. Tashevski: *Stereometrical Modeling and Presentation of objects*, Doctor Disertation, Faculty of Mechanical Engineering, 1998, Skopje, Macedonia

## STEREOMETRIJSKO PROJEKTOVANJE 3D I 4D OBJEKATA U KRIVOLINIJSKIM PROJEKTIVNIM PROSTORIMA

**Risto Taševski, Vladimir Dukovski**

*Urađen je matematički model i kompjuterski program za stereometrijsko projektovanje 3D i 4D objekata u cilindričnom, sferičnom, elipsoidnom, hiperboloidnom i paraboloidnom projektivnom prostoru. Cilj spomenutog projektovanja je realno pretstavljanje objekata iz čovekove okoline. To podrazumeva da se pretstavljeni objekti ne razlikuju od realnih. Objekti se projektuju na mrežnici očnog mehanizma. Mrežnice nemaju pravilnu geometrijsku formu, mogu se aproksimirati sa cilindričnom, sferičnom, elipsoidnom, hiperboloidnom ili paraboloidnom površinom. Znači jedini način realnog vizuelnog prikazivanja je stereometrijsko projektovanje u jednom od krivolinijskih projektivnih prostora. Da bi se dobila tri dimenziona pretstava, stereometrijski projektovani objekti u raznim projektivnim prostorima prezentovani na dvodimenzionoj ravni (hartija, ekran) uočavaju se pomoću optičkih aparata (stereoskop, naočara).*

Ključne reči: *stereometrija, krivolinijski (elipsoidan, hiperboloidan, paraboloidan) projektivni prostor.*