

## NEW TECHNIQUES FOR DAUBECHIES WAVELETS AND MULTIWAVELETS IMPLEMENTATION USING QUANTUM COMPUTING

**Saleem M. R. Taha, Walid A. Mahmood**

Department of Electrical Engineering, College of Engineering, University of Baghdad,  
Jadiryah, Baghdad, Iraq

**Abstract.** *In this paper, new techniques to implement the Daubechies wavelets and multiwavelets are presented using quantum computing synthesis structures. Also, a new quantum implementation of inverse Daubechies multiwavelet transform is proposed. The permutation matrices, particular unitary matrices, play a pivotal role. The particular set of permutation matrices arising in quantum wavelet and multiwavelet transforms is considered, and efficient quantum circuits that implement them are developed. This allows the design of efficient and complete quantum circuits for the quantum wavelet and multiwavelet transforms.*

**Key words:** *quantum computing, quantum circuits, wavelet transforms, multiwavelet transforms*

### 1. INTRODUCTION

As it happens in classical signal analysis, it is natural to expect that quantum wavelet transform will find important future applications [1] for the treatment of quantum databases and quantum data compression. Therefore, it is important to develop quantum circuits for implementing wavelet and multiwavelet transforms. Wavelets have been around since the late 1980s, and have found many applications in signal processing, numerical analysis, operator theory, and other fields [2]. The wavelet transform is a tool that cuts up data or functions or operators into different frequency components, and then studies each component with a resolution matched to its scale. The wavelet transform of a signal evolving in time depends on two variables: scale (or frequency) and time; wavelets provide a tool for time-frequency localization [3]. One generalization is multiwavelets, which have been around since the early 1990s. Multiwavelets have some advantages: they can have short support coupled with high smoothness and high approximation order, and they can be both symmetric and orthogonal. They also have some disadvantages: the discrete multiwavelet transform requires preprocessing and post processing steps. Also, the theory becomes more complicated [2].

---

Received June 09, 2013

**Corresponding author:** Saleem M. R. Taha

Department of Electrical Engineering, College of Engineering, University of Baghdad, Jadiryah, Baghdad, Iraq

E-mail: saleemtaha54@yahoo.com

In this paper, efficient and complete quantum circuits are derived for the quantum Daubechies  $D^{(4)}$  wavelet and multiwavelet transform representations. Quantum algorithms are describable in terms of unitary transformations. Fortunately, there is an important class of computations, the unitary transforms, such as the Fourier transform, Walsh-Hadamard transform and wavelet transforms, that are describable in terms of unitary operators [4]. The Fourier and Walsh-Hadamard transforms have been used most extensively by the quantum computing algorithms [5]-[11]. However, the wavelet transforms are every bit as useful as the Fourier transform; therefore it is considered, here, how to achieve a quantum wavelet transform.

The process of finding a quantum circuit that implements the unitary operator of the wavelet transform is to factor the wavelet operator into the direct sum, direct product and dot product of smaller unitary operators. These operators correspond to 1-qubit and 2-qubit quantum gates. The permutation matrices play a pivotal role in the factorization of the unitary operators that arise in the wavelet transforms. The main issue in deriving feasible and efficient quantum circuits for the quantum wavelet transforms considered in this paper, is the design of efficient quantum circuits for certain permutation matrices. The permutation matrices, due to their specific structure, represent a very special subclass of unitary matrices [4]. Therefore, the exploitation of this specific structure represents the key to achieve an efficient quantum implementation of permutation matrices. In this paper, two representative wavelet kernels are considered, the Daubechies  $D^{(4)}$  wavelets and multiwavelets. Two new decompositions which lead to gate-level circuits for their implementations are developed.

The rest of the article is organized as follows. Two fundamental quantum wavelet pyramidal and packet algorithms are introduced in Section 2, as well as quantum circuits for the perfect shuffle permutation matrices which arise in quantum wavelet transforms are discussed in this section. New quantum implementations of the most popular discrete wavelet transform, namely, the 4-coefficient Daubechies wavelet and multiwavelet transforms are developed in Section 3 and Section 4, respectively. While Section 5 deals with quantum implementation of the inverse Daubechies multiwavelet transform. Finally, the conclusion section summarizes this work.

## 2. WAVELET PYRAMIDAL AND PACKET ALGORITHMS

Given a wavelet kernel, its corresponding wavelet transform is usually performed according to a packet algorithm (*PAA*) or a pyramid algorithm (*PYA*). The first step in devising quantum counterparts of these algorithms is the development of suitable factorizations. Consider the Daubechies fourth-order wavelet kernel of dimension  $2^i$ , denoted as  $D^{(4)}_{2^i}$ . The factorizations of *PAA* and *PYA* for a  $2^n$ -dimensional vector are given as [4].

$$PAA = (I_{2^{n-2}} \otimes D_4^{(4)}) (I_{2^{n-3}} \otimes \Pi_8) \cdots (I_{2^{n-i}} \otimes D_{2^i}^{(4)}) \times \\ (I_{2^{n-i-1}} \otimes \Pi_{2^{i+1}}) \cdots (I_2 \otimes D_{2^{n-1}}^{(4)}) \Pi_{2^n} D_{2^n}^{(4)} \quad (1)$$

$$PYA = (D_4^{(4)} \oplus I_{2^{n-4}}) (\Pi_8 \oplus I_{2^{n-8}}) \cdots (D_{2^i}^{(4)} \oplus I_{2^{n-2i}}) (\Pi_{2^{i+1}} \oplus I_{2^{n-2i+1}}) \cdots \\ \cdots \Pi_{2^n} D_{2^n}^{(4)} \quad (2)$$





This description of  $Q_2^n$  allows its quantum implementation and hence  $D_{2^n}^{(4)}$  by using quantum arithmetic circuits with a complexity of  $O(n)$ . Whereas, in classical solutions there are known algebraic techniques for factoring an arbitrary  $2^n \times 2^n$  operator, they are guaranteed to produce  $O(2^n)$  [4], i.e., exponentially many, terms in the factorization. Hence, although such a factorization is mathematically valid, it is physically unrealizable, because when treated as a quantum circuit design, would require too many quantum gates. It is therefore clear that for achieving an efficient quantum implementation, i.e., with a polynomial time and space complexity, it is necessary to exploit the specific structure of the given unitary operator.

In the following, it is shown how a circuit for  $|m\rangle \rightarrow |m - 1 \bmod 2^n\rangle$  can be constructed. In binary representation, this mapping can be specified in terms of the following operations:

$$|a_{n-1} \dots a_1 a_0\rangle \rightarrow |b_{n-1} \dots b_1 b_0\rangle, \text{ with}$$

$$b_0 = a_0 \oplus 1$$

$$b_1 = a_1 \oplus a_0 \oplus 1 = a_1 \oplus b_0$$

$$b_2 = a_2 \oplus c_1, \text{ where } c_1 = b_0 b_1$$

$$b_3 = a_3 \oplus c_2, \text{ where } c_2 = b_2 c_1$$

$$b_i = a_i \oplus c_{i-1}, \text{ where } c_{i-1} = b_{i-1} c_{i-2}$$

Calculating the  $c_i$ 's and then the  $b_i$ 's, the circuit in Fig.4 is obtained. Replacing the block  $Q_n^2$  in Fig.3 with the circuit in Fig.4, then Fig.3 represents a complete gate-level circuit for implementation of  $D_{2^n}^2$ .

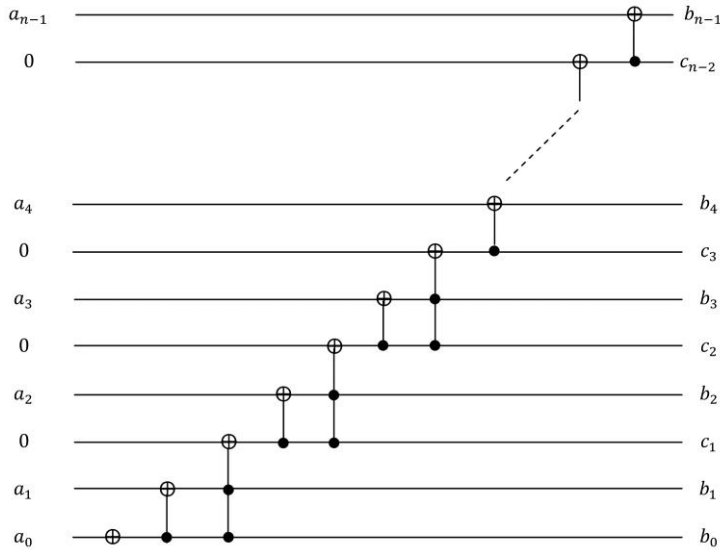
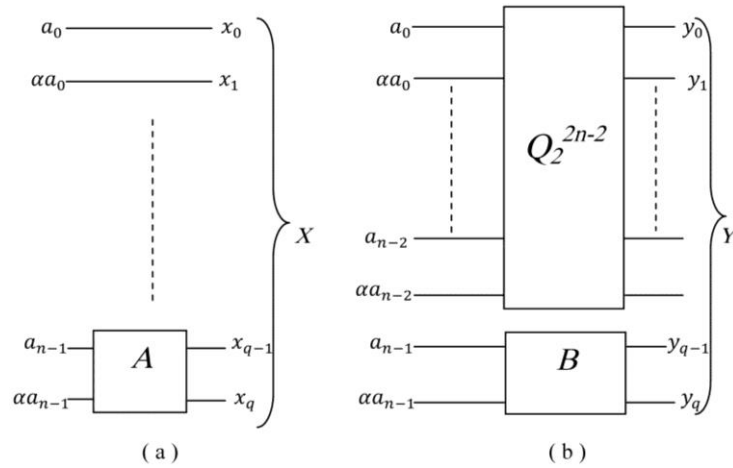

**Fig. 4** A new circuit for implementation of permutation matrix  $Q_n^2$





register (initially loaded in state  $|Y\rangle$ ) should be of size  $q+1$  if both  $X$  and  $Y$  are encoded on  $q$  qubits. In addition, a temporary register of size  $q$  is required, initially in state  $|0\rangle$ , to which the carries of the addition are written (the last carry is the most significant bit of the result and is written in the last qubit of the second register) [12].



**Fig. 5** The realizations of: (a) Eq. (14), (b) Eq. (17); where  $q = 2n - 1$ .

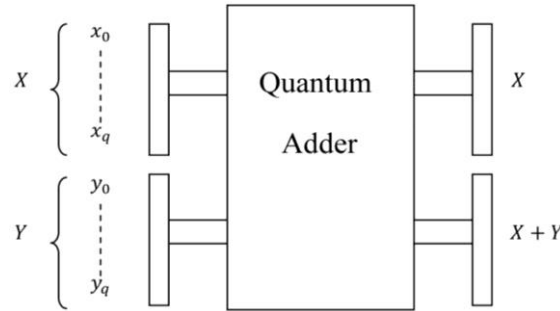

**Fig. 6** The realization of the Daubechies  $D^{(4)}$  multiwavelet transform.

### 5. QUANTUM IMPLEMENTATION OF INVERSE DAUBECHIES $D^{(4)}$ MULTI-WAVELET TRANSFORM

A new quantum implementation of inverse Daubechies  $D^{(4)}$  multiwavelet transform is proposed here, as follows.

The reconstruction matrix  $R$ , Eq. (19), which is the transformation matrix  $T$  transposed, can be decomposed as the summation of two matrices  $Z$  and  $W$ .



$$R = \begin{pmatrix} H_0 & G_0 & \cdot & \cdot & \cdot & & & H_2 & G_2 \\ H_1 & G_1 & \cdot & \cdot & \cdot & & & H_3 & G_3 \\ H_2 & G_2 & H_0 & G_0 & & & & & \\ H_3 & G_3 & H_1 & G_1 & & & & & \\ & & H_2 & G_2 & & & & & \\ & & H_3 & G_3 & & & & & \\ & & & & \cdot & & & & \\ & & & & & \cdot & & & \\ & & & & & & & H_0 & G_0 \\ & & & & & & & H_1 & G_1 \end{pmatrix} \quad (19)$$

The matrix  $Z$  is shown below:

$$Z = \begin{pmatrix} H_0 & G_0 & \cdot & \cdot & \cdot & & & & & \\ H_1 & G_1 & \cdot & \cdot & \cdot & & & & & \\ & & H_0 & G_0 & & & & & & \\ & & H_1 & G_1 & & & & & & \\ & & & & \cdot & & & & & \\ & & & & & \cdot & & & & \\ & & & & & & & H_0 & G_0 \\ & & & & & & & H_1 & G_1 \end{pmatrix} \quad (20)$$

The matrix  $Z$  can be described as:

$$Z = I_{2^{2n-2}} \otimes C \quad (21)$$

where

$$C = \begin{bmatrix} H_0 & G_0 \\ H_1 & G_1 \end{bmatrix} \quad (22)$$

The  $H_0, H_1, G_0$  and  $G_1$  are as given in Equations (10) and (11), respectively.

The matrix  $W$  is:

$$W = \begin{pmatrix} & & \cdot & \cdot & \cdot & & & H_2 & G_2 \\ & & \cdot & \cdot & \cdot & & & H_3 & G_3 \\ H_2 & G_2 & & & & & & & \\ H_3 & G_3 & & & & & & & \\ & & & & \cdot & & & & \\ & & & & & \cdot & & & \\ & & & & & & & H_2 & G_2 \\ & & & & & & & H_3 & G_3 \end{pmatrix} \quad (23)$$

The matrix  $W$  can be described as:

$$W = Q_{2^{2n-2}}^t \otimes D \quad (24)$$

where,

$$Q_{2^{2n-2}}^t = \begin{bmatrix} 0 & 0 & & 1 \\ 1 & 0 & \cdots & 0 \\ 0 & 1 & & 0 \\ \vdots & & \ddots & \vdots \\ 0 & 0 & \cdots & 1 & 0 \end{bmatrix} \quad (25)$$

and

$$D = \begin{bmatrix} H_2 & G_2 \\ H_3 & G_3 \end{bmatrix}. \quad (26)$$

The  $H_2$ ,  $H_3$ ,  $G_2$  and  $G_3$  are as given in Eqs. (10) and (11), respectively. The realization of Eq. (21) is similar to that of Eq. (14). Also, the realization of Eq. (24) is similar to that of Eq. (17), but the  $Q_{2^{2n-2}}^t$  (i.e. the transpose of the downshift permutation matrix) is used instead of  $Q_{2^{2n-2}}$ . Fig. 7 shows the entire quantum implementation of the inverse  $D^{(4)}$  multiwavelet transform.

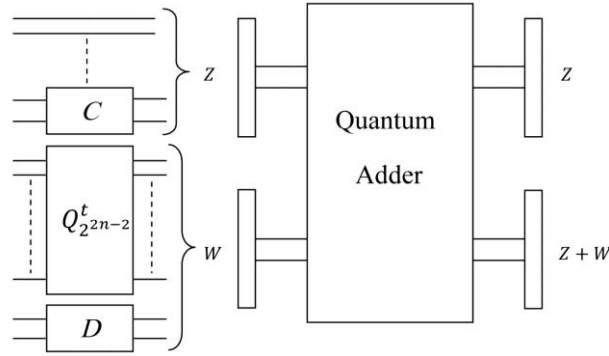

**Fig. 7** Implementation of the inverse Daubechies  $D^{(4)}$  multiwavelet transform.

The quantum arithmetic description of  $Q_{2^n}^t$  is given as:

$$Q_{2^n}^t : |a_{n-1} a_{n-2} \dots a_1 a_0\rangle \rightarrow |b_{n-1} b_{n-2} \dots b_1 b_0\rangle$$

where  $b_i = a_i + 1 \pmod{2^n}$ .

This description of  $Q_{2^n}^t$  allows its quantum implementation. Hence, it is required to construct a quantum circuit for  $|m\rangle \rightarrow |m + 1 \pmod{2^n}\rangle$ . In binary representation, this mapping can be specified in terms of the following operations:

$$|a_{n-1} a_{n-2} \dots a_1 a_0\rangle \rightarrow |b_{n-1} b_{n-2} \dots b_1 b_0\rangle, \text{ with}$$

$$b_0 = a_0 \oplus 1$$

$$b_1 = a_1 \oplus a_0$$

$$b_2 = a_2 \oplus c_1, \text{ where } c_1 = a_1 a_0$$

$$b_i = a_i \oplus c_{i-1}, \text{ where } c_{i-1} = a_{i-1} c_{i-2} \text{ for } 3 \leq i \leq n-1$$

Calculating the  $c_i$ 's and then the  $b_i$ 's, the circuit in Fig. 8 is obtained.

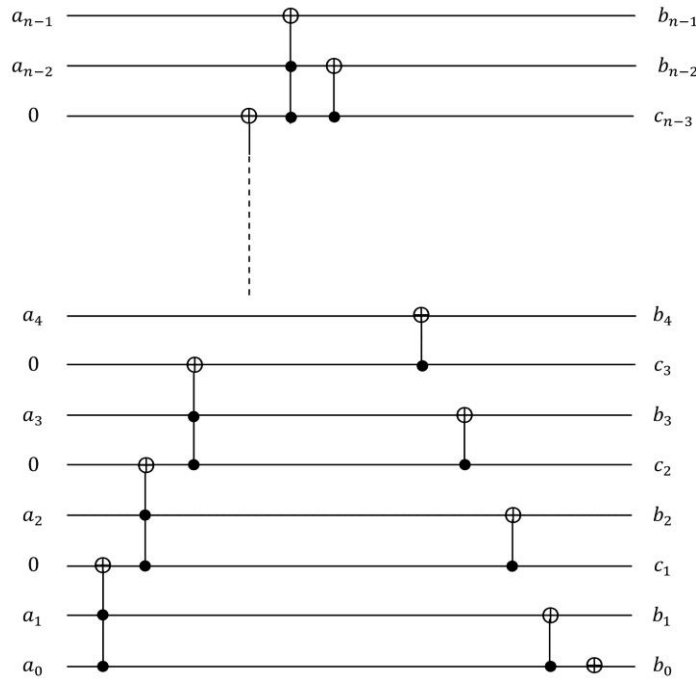

**Fig. 8** A new circuit for implementation of permutation  $Q_2^n$  matrix.

## 6. CONCLUSIONS

In this paper, fast algorithms for quantum Daubechies  $D^{(4)}$  wavelet, multiwavelet and inverse multiwavelet transforms are developed. Three complete circuits for these three types of Daubechies  $D^{(4)}$  transforms are described. Permutation matrices  $I_2^n$ ,  $Q_2^n$ , and  $Q_2^t$  play a pivotal role in the development of the three types of transform. In fact, not only they arise explicitly in the packet and pyramid algorithms but also they play a key role in factorization of wavelet kernels and in decomposition of multiwavelet and inverse multiwavelet transforms.

In this paper, the Daubechies quantum wavelet and multiwavelet transforms are implemented. In a similar manner, the other types of wavelet and multiwavelet transformations can be achieved (a promising task for the future).

## REFERENCES

- [1] M. Terraneo and D. L. Shepelyansky, "Imperfection Effects for Multiple Applications of the Quantum Wavelet Transform", *Physical Review Letters*, vol. 90, no.25, pp. 257902-(1-4), 2003.
- [2] F. Keinert, *Wavelets and multiwavelets*. Chapman & Hall/CRC, 2004.
- [3] I. Daubechies, *Ten lectures on wavelets*. Philadelphia: SIAM, 1992.
- [4] A. Fijany and C. P. Williams, "Quantum wavelet transforms: fast algorithms and complete circuits", 1st NASA International Conference on Quantum Computing and Communication. Palm Spring, CA, Feb. 17-21, 1998. Available: [www. arXiv: quant-ph/9809004v1](http://www.arXiv.org/abs/quant-ph/9809004v1), 1998.

- [5] S. Imre and F. Balazs, *Quantum computing and communications: an engineering approach*. John Wiley & Sons Ltd, 2005.
- [6] P. Kaye, R. Laflamme and M. Mosca, *An introduction to quantum computing*. Oxford University Press Inc., 2007.
- [7] M. A. Nielsen and I. L. Chuang, *Quantum computation and quantum information*. Cambridge University Press, Cambridge, UK, 2000.
- [8] R. Jozsa, "Quantum algorithms and the Fourier transform", Los Alamos preprint archive (1997). Available: <http://xxx.Lanl.Gov/archive/quant-ph/9707033>, 1997.
- [9] A. Barenco, A. Ekert, K-A Suominen and P. Torma, "Approximate quantum Fourier transform and decoherence", *Physical Review A*, vol. 54, no. 139, Jan. 21, 1996. Available: [www.arXiv: quant-ph/9601018v1](http://www.arXiv.org/quant-ph/9601018v1), 1996.
- [10] P. Høyer, "Efficient quantum transforms", Feb. 12, 1997. Available: <http://xxx.lanl.gov/archive/quant-ph/9702028>, 1997.
- [11] A. Klappenecker, "Wavelets and wavelet packets on quantum computers", Sep. 3, 1999. Available: <http://xxx.Lanl.gov/archive/quant-ph/9909014v1>, 1999.
- [12] V. Vedral, A. Barenco, A. Ekert, "Quantum network for elementary arithmetic operations", *Physical Review A*, vol.54, no. 147, 1995. Available: [www.arXiv.org/quant-ph/9511018v1](http://www.arXiv.org/quant-ph/9511018v1), 1995.