

**THE STATIC ATMOSPHERIC ELECTRICITY AND  
INSULATION PROBLEMS OF HIGH-POWER  
M.F. MAST ANTENNAS**

**Jovan Surutka**

**Abstract.** After a brief survey of problems related to the static atmospheric electricity and insulation of stay ropes of MF and LF broadcast tower antennas is presented, the following theoretical contributions and technical solutions to these problems, given by research team at Faculties in Belgrade and Nish, are reviewed:

- 1° An efficient method for computing the electrostatic fields in the surroundings of the stayed masts, as well as the voltages on stay insulators;
- 2° A method for eliminating the static electricity from stays by draining coils;
- 3° The design of a quarter wavelength monopole antenna supported by non insulated stay ropes;
- 4° A novel approach to the design of insulators in MF tower broadcast antenna stays, and, finally,
- 5° An efficient solution for protecting the ends of synthetic-fibre stay ropes against strong electric fields.

## 1. Introduction

For broadcasting the radio programmes on medium and long waves the most commonly used type of the antenna is the vertical steel mast, insulated and driven in its base, and kept in the upright position by means of steel stay ropes (Fig. 1). The height of the antenna mast is between 0.1 and 0.65 of the operational wave-length ( $\lambda$ ), depending on the desired vertical radiation pattern and radiated power. In the lower part of the medium-frequency band (MF) the physical antenna heights are up to 300m, which corresponds to the antennas having the so-called antifading radiation pattern. In the

---

Manuscript received September 13, 1995.

The author is the member of the Serbian Academy of Science and Art, Knez Mihajlova 35, 11000 Beograd.

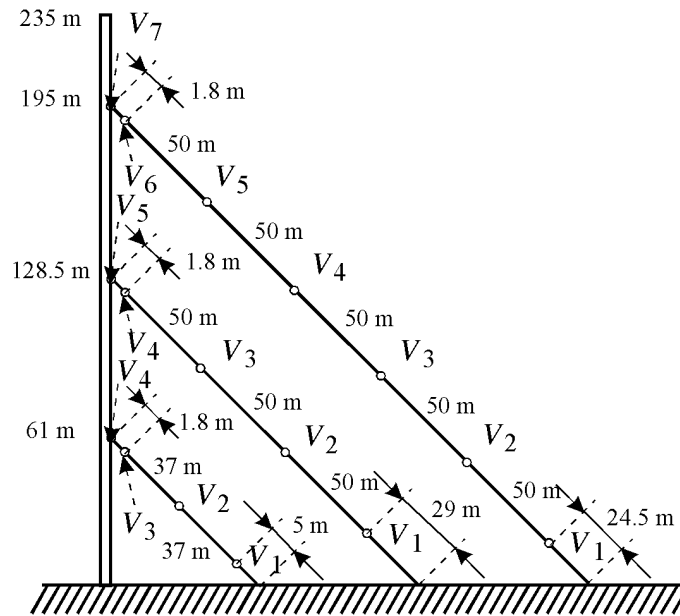

Figure 1. The configuration of stays and insulators in the MF antenna of Radio Belgrade ( $f = 684kHz$ ,  $P = 200kW$ ,  $h = 235m$ )

low-frequency (LF) band antifading antennas are not feasible and, up to now, the tallest LF antenna is 500m high. Antennas the height of which exceeds several tens meters must be stayed at several levels.

In order to suppress the induced radio-frequency currents in the ropes and their unwanted radiation, the stay are normally divided into short sections by stay rope insulators, as indicated in Fig. 1. The sectionalized stay ropes are also used with other types of transmitting MF and LF antennas, such as T- or inverted L- antenna, or shunt-fed antenna.

The insulators are subject to two kinds of voltages:

- 1° induced radio-frequency (RF) voltages, due to RF current in the antenna mast; and
- 2° electrostatic voltages due to atmospheric electrostatic field in the vicinity of the antenna.

While the RF voltages are practically constant in time and depend on the radiated power, the electrostatic voltages are variable and can reach very high values. Immediately before and during thunderstorms electrostatic voltages as high as 200 to 300, and even 400kV across an insulator

are often encountered. They are a consequence of very strong atmospheric electrostatic fields between clouds and the earth. Simpson and Scarse [1] quote maximal field strengths of  $5 - 10kV/m$ . In spite of the use of very expensive and bulky stay rope insulators, the mentioned high voltages can produce flash-overs between the metal fittings at either end of an insulator and, hence, other much heavier consequences can follow.

The static discharge across the stay rope insulators is a problem which plagues many high-power MF and LF broadcast stations having high guyed mast-antennas. Although the problem was espied and described as early as 1939, in the classical paper of Brown [2], it is becoming of growing importance at the present time with steady increase of powers of MF and LF transmitters, which frequently exceed several hundred and even thousand kilowatts.

Therefore, recently, greater attention has been paid to this problem in the specialized literature and several papers, devoted to the study of the influence of the electrostatic and RF fields on the stay rope insulators, have been published [3, 10]. In a paper by professor Veličković and mine, Ref. [4], which is often cited in the literature, an accurate method for computing the electrostatic field in the surroundings of a stayed antenna mast and the electrostatic voltages across the stay ropes insulators, is presented.

The method is based on an integral equation technique, where the integral equation is approximately solved by the so-called point-matching method. The unknown sub integral functions, representing the charge densities per unit length of conductors have been approximated by polynomials with unknown coefficients. Apart from the fact that the true distribution function can be well approximated by a low order polynomial, the polynomial approximation leads to integrals, which, by means of recurrent formulas, can be reduced to elementary integrals.

The previously quoted large static voltages were calculated using this method. The paper [4] is cited as an important reference in the CCIR Report 943, XVIth Plen. Ass., October 1986.

The static voltages and the flashovers they cause are not, in themselves, particularly dangerous when the transmitter power is low. Problems arise, however, in the case of high-power transmitters. Once the static voltage has caused a break-down of the insulator spark gap, the induced RF voltage can maintain the arc even if the voltage is much less than that needed to trigger a flashover.

If the arc occurs at the insulator which connects the stay to the mast structure, there will be appreciable change in the antenna feed point

impedance and the transmitter's reflectometer protection system will momentarily interrupt the transmission thus extinguishing the arc. The only fault in this case will be a very short break in transmission.

In contrast, a flashover across an insulator which is not in contact with the mast will not activate the reflectometer and RF energy will maintain the arc; in high-power transmitters the power in the RF arc can be considerable and the resulting thermal stresses may damage the insulator. As an example, an old ceramic stay insulator (of the MF antenna of Radio Belgrade) damaged by RF arcing is shown in Fig. 2.

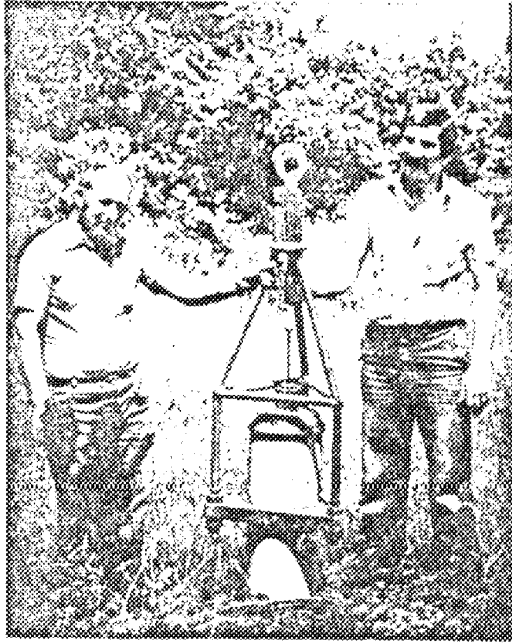

Figure 2. An old ceramic stay insulator damaged by RF arcing

In the absence of a system serving to extinguish such arcs, the safety of the mast can be jeopardized. In particular, prolonged arcing can cause catastrophic damage to strain insulators in which the fittings are not interlinked. In any event, the replacement of a broken insulator is time-consuming and costly.

Contrary to what might be expected, a lightning strike which touches the mast directly or which falls in the immediate vicinity represents an incomparably smaller risk as regards antenna safety than a flashover triggered by the general level of the electrostatic field. A direct strike will cause

flashovers on all the insulators on a stay and this, in turn, will trigger the reflectometer, interrupting the transmission.

## 2. Methods for protecting a mast antenna from atmospheric static discharges

In order to avoid annoying or even dangerous consequences caused by the static atmospheric electricity, several methods have been suggested and developed.

The oldest and most commonly used method for avoiding static discharges and accompanying RF arcs is the use of high-resistance static leak resistors connected in parallel to each insulator, except to those which connect the stays to the antenna mast structure [2]. These resistors leak the electric charge from the stays to the earth, thus preventing the accumulation of static voltages. Although this may seem to be an ideal solution of the problem, it is far from being perfect in practice: a direct or near stroke may destroy the resistor, so that the insulators remain unprotected with no visible indication.

In recent times special arc detectors, sensitive to the ultraviolet radiation or RF noise emitted by an arc, have been developed. Another interesting form of detector measures the RF currents in the lowest section of the stays by means of current transforms and compares them. When an arc occurs, these detectors activate protection devices which interrupt the transmission for a short interval and extinguish the arc. If the system operates correctly, the number of these interruptions may be so high during stormy weather and immediately before it, that listening to the program becomes unpleasant.

Since the arc detectors remove the consequences, but not the cause, of arcs, some completely new technical solutions which avoid the use of stay insulators have recently been proposed and realized. Among these the most notable are:

- 1° The replacing the steel stays by plastic ones;
- 2° The use of self-supporting towers; and
- 3° The use of certain antenna types with steel stays without insulators.

Non-metallic stays are made of modern synthetic fibbers. Although these have remarkable electrical and mechanical properties, there is still insufficient experience of their behavior over a long period of time. Also, the material is non resistant to high temperature and fire.

Self-supporting tower antennas have neither stays, nor insulators, so there are not problems regarding static voltages, but they have two serious

shortcomings: high price, and a wide and varying tower cross-section, which makes it impossible to obtain a proper anti-fading vertical radiation pattern, if such pattern is required.

Attempts have been made in recent years to construct stayed antennas without insulators [5, 13]. The main disadvantage of this approach is that they cannot provide an anti-fading radiation pattern owing to the strong RF currents in the stays.

The shortcomings of the various technical solutions described above reaffirm (at the present state of the art and particularly in the case of tall anti-fading antennas) the preference for slender mast with insulated steel stays, provided that an effective system can be devised for eliminating static discharges.

That solution, efficient and simple, was proposed and realized by the present author in 1977 [9, 10], during the reconstruction of the antenna of the main MF transmitter of Radio Belgrade.

### 3. The new anti-static system on the MF antenna of Radio Belgrade

Ever since the antenna for the main MF transmitter of Radio Belgrade ( $684kHz$ ) came into service, during 1949, there have been difficulties when transmitting during thunderstorms owing to the build-up of static charges on the stays. In fact the problems were considerably less common at first when the transmitter power was only  $150kW$ , but when it was increased to  $400kW$ , and more recently to  $2000kW$ , the problems became more frequent.

The MF antenna of Radio Belgrade is a steel lattice mast  $235m$  high; it is of triangular cross-section with sides of  $2.2m$ . The mast is held in vertical position by nine steel stays, arranged in three levels (three stays in each level). The stays are divided into sections with stay insulators; the configuration as it was prior to the reconstruction work done in 1975 is shown in Fig. 1 (only stays in a vertical plane are presented).

During the preparatory work for this reconstruction, theoretical studies were conducted concerning the static as well as RF voltages on the stay insulators. The static voltages, assuming an electrostatic field of  $10kV/m$ , are calculated using already mentioned method described in [4]. The numerical results are shown in Table 1.

As far as the RF voltages are concerned, professor Veličković in his Ph. doctoral dissertation (Ref. [6]) proposed an efficient method for evaluating these voltages. The method consists in evaluating the RF field produced by the antenna without stays, assuming that the presence of the stays does not

significantly influence the antenna current distribution. Integral equations of the Hallèn type for the current distribution in stays with insulators are then formulated, considering each stay at a time to be situated in the impressed RF electric field produced by the antenna alone. These equations are solved by the point-matching method with a polynomial approximation of the current distribution. By using this method the RF voltages on the stay insulators, corresponding to a radiated power of  $2000\text{kW}$ , are calculated and presented in Table 1. These theoretical values agree very closely with the experimental data.

Table 1. Calculated static and RF voltages, in  $\text{kV}$ , across stay insulators for static field strength of  $10\text{kV/m}$ , and RF power of  $2000\text{kW}$

Top stay						
	$V_1$	$V_2$	$V_3$	$V_4$	$V_5$	$V_6$ and $V_7$
Static	322	306	268	177	144	958
RF	1.1	2.7	2.9	3.1	4.5	21.6

Middle stay				
	$V_1$	$V_2$	$V_3$	$V_4$ and $V_5$
Static	308	222	12	543
RF	4.0	4.5	4.2	7.4

Bottom stay			
	$V_1$	$V_2$	$V_3$ and $V_4$
Static	126	62	188
RF	4.0	11.6	26.0

By comparing the static and RF voltages shown in the Table 1, it is evident that the former are predominant and very large.

In order to ensure adequate RF insulation for the  $2000\text{kW}$  radiated power, coupled with an adequate mechanical safety margin, the contractors (Firm Continental Electronics, Dallas, USA) proposed an arrangement of four fibre-glass rods in parallel for each insulator. This form of construction was chosen primarily because of its light weight: the contractor's experts believed that the mast (more than 27 years old) could not support the increased weight of conventional ceramic girdle-band insulators for the increased RF voltages. Another advantage of the fibre-glass insulators was their relatively low cost, although this was not a decisive factor.

Unfortunately, the chosen insulators had two serious shortcomings which had a direct bearing on the problem of static discharge and mast

safety. The first was the poor resistance of the fibre-glass to the high temperatures that can occur during arcing. To keep the arc as far as possible from the rods, two field-grading rings were placed around the rods, each being connected to the metal fittings at one end of the insulator. The second shortcoming which affected mast safety stemmed from the constructional design of this form of insulator. The rods are under tension and the metal parts at either end are not interlinked as in the case with conventional ceramic girdle-band insulators. Consequently, in the event of mechanical or thermal destruction of an insulator, the corresponding stay will be severed completely and the entire mast will fall to the ground. After the insulators had been installed and the transmitter power had been raised to 2000 kW, problems with static discharges increased to such an extent that transmissions became impossible during thunderstorms: static flashovers and RF arcs were so frequent that the transmitter had to close down in such conditions. Although these interruptions were unpleasant and inadmissible, the worst consequence of the static discharges was a constant fear in the minds of the station staff that the stability of the mast might be jeopardized.

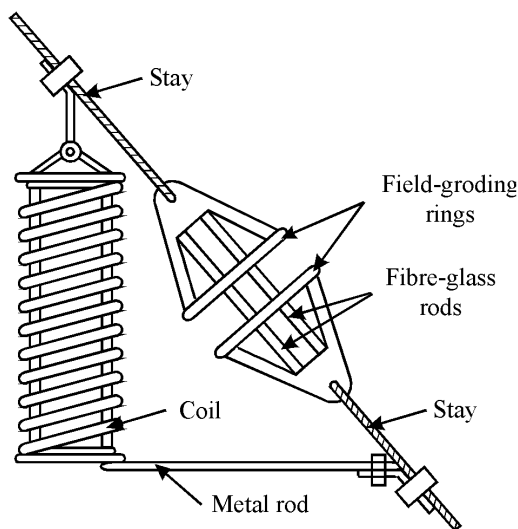

Figure 3. Sketch of the static drain coil connected in parallel with the stay insulator

Confronted with a serious situation requiring a rapid solution, the transmitter experts of Radio Belgrade set about solving the problems themselves. Experience to date suggests that their solution was indeed a good one. Not



only is it very effective, but it has the added merit of being extremely simple: it involves the connection of static drain coils in parallel with all stay insulators, except those immediately adjacent to the mast (Fig. 3). The coils act in a similar manner to static leak resistors, draining static charges to earth. The coil inductance was calculated so that a parallel resonant circuit would be formed with the insulator capacitance at the transmitter carrier frequency. Not only does this eliminate the accumulation of static charges, it also results in an appreciable increase in the RF impedance between the stay sections.

The system was put in operation in April 1977 and since that time there has been no recurrence of the problems experienced earlier as result of atmospheric electrostatic fields.

The references [9, 10], concerning the new anti-static system, are also cited in CCIR Report 943, XVIth Plen. Ass., October 1986.

#### **4. A novel approach to the design of insulators in MF tower broadcast antenna stays**

The elimination of dangerous static voltages from stay insulators leaves only relatively small, steady and predictable RF voltages. This fact changes the basic philosophy on the insulator design. Instead of expensive and bulky insulators designed for high voltages, the draining coils enable much cheaper and lighter insulators to be used, which are designed to withstand only relatively small RF voltages. The novel design approach was first applied in the design of stay insulators of the new MF broadcast antenna of Radio Podgorica (1987) [11].

The design procedure now requires a suitable method for evaluating these RF voltages with sufficient accuracy.

In [11] a new and very precise method for the evaluation of RF voltages on stay insulators has been proposed. The antenna mast, stays and insulators are considered as an integral wire structure. Thus, the influence of the stays on the antenna radiation pattern and the input impedance, as well as the mutual influence of the stays are properly taken into account. For the analysis of the wire structure, the method described in Reference [12] was adopted, which was modified for the present purpose. By including the analysis technique into an optimization procedure it is possible to design a complete system of stay insulators.

The method was applied in the design of the stay insulators of the mentioned new MF antenna of Radio Podgorica. The antenna operating frequency is  $882\text{kHz}$ , and the unmodulated carrier power is  $600\text{kW}$ . The

mast height is about  $185m$ . The mast has four levels of stays, which are arranged in the three vertical planes, symmetrically placed at  $120^\circ$  angles. In Fig. 4 only stays in one plane are shown.

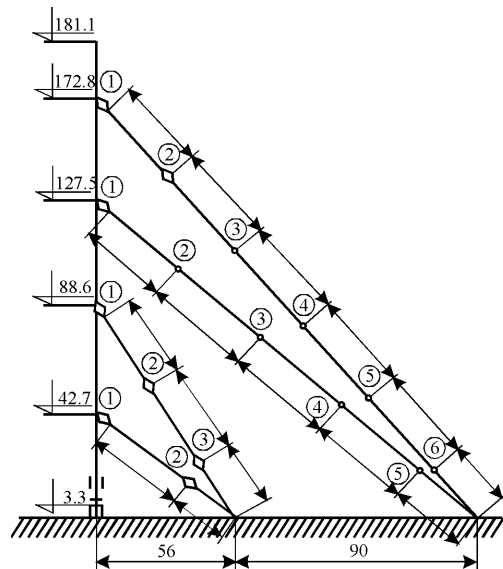

Figure 4. The configuration of the stays and insulators in the MF antenna of Radio Podgorica ( $f = 882 \text{ kHz}$ ,  $P = 600 \text{ kW}$ ):  
 ○ egg-shaped insulators, ◇ fibre-glass rod insulators.

As a result of the optimization procedure an arrangement of stay insulators shown in Fig. 4 is obtained. The calculated RF insulator voltages, corresponding to a power of  $600 \text{ kW}$  (at a modulation of 100%), are presented in Table 2.

Table 2. Maximum RMS insulator voltages in  $kV$  for the antenna shown in Fig. 5.

Insul. no.	1st stay	2nd stay	3rd stay	4th stay
1	19.5	7.3	10.4	24.8
2	6.1	2.7	9.1	9.6
3	2.3	2.2	6.4	
4	2.1	1.5		
5	1.7	1.4		
6	1.6			

Owing to the fact that the static-charge draining coils are placed across all the insulators except those connected to the mast (the mast has its own

draining coil at its base), the static voltages are not present on the stay insulators. The insulators are only exposed to the relatively small RF voltages, the highest of which are present at the insulators which are connected to the mast. This fact enables the use of very cheap and light egg-shaped insulators at the majority of insulation points. The flashover voltage of this type of insulators in wet conditions is  $14\text{ kV}$  (at  $300\text{ kHz}$ ). Taking a safety margin of about 3 (i.e. the maximum RMS voltage across an insulator must not exceed  $1/3$  of the flashover voltage), the egg-shaped insulators can be used in all points where the r.f. voltage do not exceed  $4.7\text{ kV}$ . In other places the electrically more reliable insulators made of fibre-glass rods are utilized. These rods are arranged in baskets (two rods in a basket) similar to those in Fig. 3.

### **5. A quarter-wavelength transmitting monopole antenna supported by noninsulated stay ropes**

As mentioned in Section 2, one of the ways for avoiding the atmospheric static discharges and their consequences is in the use, if possible, of certain antenna types with steel stays without insulators.

Recently we have had the opportunity to develop and construct a new transmitting monopole without stay-rope insulators [13]. The antenna is conceived as a vertical quarter-wavelength monopole, insulated and fed at its base, and kept in the upright position by means of three non insulated stay ropes. At the upper end the ropes are directly connected to the antenna mast and earthed at the lower end (Fig. 5). The antenna can also be treated as a kind of distorted folded monopole, without skirt, the stays of which play the role of the earthed conductor. The tower and stay ropes cross-sections are determined by mechanical considerations.

In order to reduce losses in the ground, the mast base as well as the three anchoring points of the stay ropes must be supplied with their own radial grounding systems. A detailed analysis has shown that the main grounding system at the mast base should be similar to that of a usual monopole antenna (for example, 120 wire conductors, each half wave long), but those at the anchoring points can be much smaller.

The theoretical analysis was performed by using general method presented in Reference [12].

Since the antenna was intended to serve as a stand-by antenna for the main MF transmitter of Radio Belgrade ( $2000\text{ kW}$ ), radiating on  $684\text{ kHz}$ , the height of the antenna mast of  $110\text{ m}$  has been adopted ( $\lambda/4$ ). In order

to properly design the position of the anchoring point of the stay ropes to the tower, the height  $h_a$  (Fig. 5) was varied between  $60m$  and  $100m$ . In this range, the antenna input impedance varied within the limits of  $\pm 5\%$  about  $140\Omega$ , while the reactance varied within the limits of  $\pm 20\Omega$  about  $100\Omega$ . Since these variations were relatively insignificant, it was adopted  $h_a = 79.2m$ , since this height is optimal from the mechanical standpoint. On the other side the input impedance has a very convenient value (about  $140\Omega$ ), which enables easy matching to the open-wire feeders.

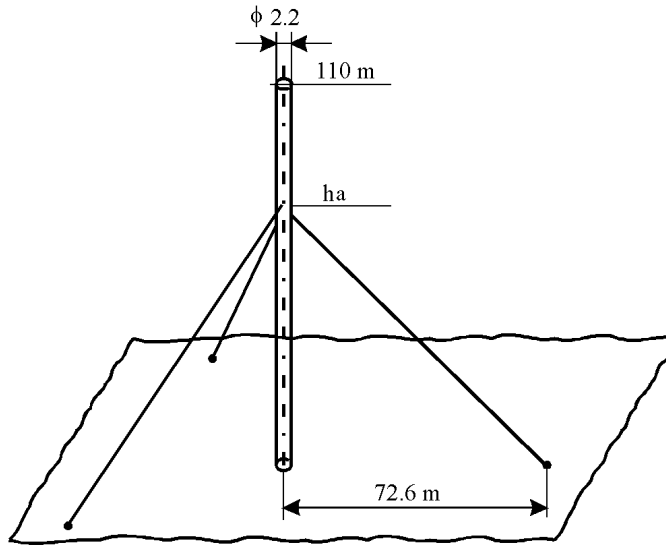

Figure 5. Sketch of a monopole antenna with noninsulated guy ropes

Due to the lack of expensive and bulky stay rope insulators and accompanying problems with the electric discharge and arcing, such an antenna is very suitable for extremely large powers. The only disadvantage for larger application of the antenna in the MF broadcasting is that it cannot provide the anti-fading radiation pattern. The vertical and horizontal radiation patterns of this antenna are very close to those of a quarter-wavelength monopole. In those cases where sky-wave broadcasting to moderately distant areas is needed, this antenna is very convenient.

Owing to its good characteristics, the described new antenna has been adopted as the stand-by antenna for the main MF transmitter of Radio Belgrade ( $2000 kW$ ).

## 6. The protection of the ends of the synthetic fibre stay ropes against strong electric fields

The up-to date technology of synthetic fibres offers the fibre-glass ropes having highly valuable electrical and mechanical characteristics. Being an excellent dielectric and having better resistance to breaking than the standard steel rope of the same diameter, the synthetic-fibre rope seems to be an almost ideal means for staying large-power MF and LF mast antennas. With this kind of stays there is no need for expensive and bulky insulators for sectioning ropes and, what is more important, there are no problems with RF arcing.

Though all these advantages have been known for several years, synthetic fibre ropes did not yet find an adequately large application in the construction of large-power MF and LF transmitting antennas. The reason for that is, it seems, to be sought in the low resistance of fibres to high temperature.

Except a direct strike of the lightning into the rope, which is very little probable, the sole sources of high temperature and thermal damages can be long-term discharges and creeping currents at the rope end, caused by the strong static and RF fields on the sharp edges of inadequately shaped heads of ropes. Such a head, produced by manufacturer of ropes is shown in Fig. 6. The shortcoming of this head was viewed by Gregorač [14], who proposed a new form of the head, where the field in the vicinity of the rope's surface is considerably reduced (Fig. 7). The new head form is patented and from rope's manufacturer accepted.

In a relatively recent paper of mine and Marković [15] a further attempt was made for improving the protection of the ends of the synthetic-fibre ropes for staying mast antennas against strong electric fields. In addition to the suitable shaping of the metallic head terminating the rope, very significant reduction of the field strength on the head and rope end can be achieved by putting a thoroidal protecting electrode coaxially to the head (Fig. 8). The thoroidal electrode is mechanically as well as conductively connected to the metal head and has the same potential. The dimensions defining geometry of the thoroidal electrode are:  $R$  - the mean radius of the torus,  $r$  - the radius of its cross-section, and  $z_0$  - the height of the center of torus above the head bottom.

Using a numerical procedure, based on the charge simulation method (CSM), the effect of the thoroidal electrode on the electric field intensity at the head's critical points and on the surface of the rope in the vicinity of the

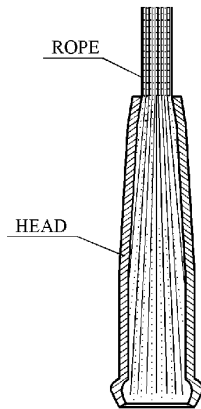

Figure 6. A typical metallic head of a fibre-glass stay rope

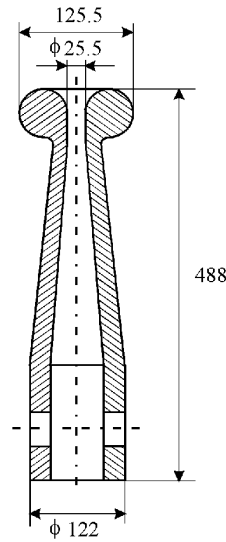

Figure 7. The new form of the head proposed by Gregorač

head was investigated. A rope having diameter  $25\text{mm}$  and corresponding head proposed by Gregorač were taken as a base.

The protective influence of the thoroidal electrode was investigated by putting the head, together with the synthetic rope and protecting electrode (and without it) into the homogeneous electric field, of intensity  $E_0$ , normal to the conducting plane (Fig. 8).

In order to determine the optimal dimensions and the position of the thoroidal electrode, the evaluations of the field intensities in a large number of points on the surfaces of the head, rope and thorus were performed for 36 combinations of parameters  $R$ ,  $r$  and  $z_0$ . The following set of values for  $R$ ,  $r$  and  $z_0$  has been selected:

$$\begin{aligned} R &= 0.200\text{ m}, & 0.250\text{ m}, & 0.300\text{ m}, \\ z_0 &= 0.550\text{ m}, & 0.625\text{ m}, & 0.700\text{ m}, \\ r &= 0.025\text{ m}, & 0.035\text{ m}, & 0.040\text{ m}. \end{aligned}$$

Only a small part of the obtained results concerning the field strengths on the thoroidal crown of the head and along the rope, is presented here.

On the left side of Fig. 8 the polar diagram, drawn by dotted line, represents the electric field strength on the crown of the head in the absence

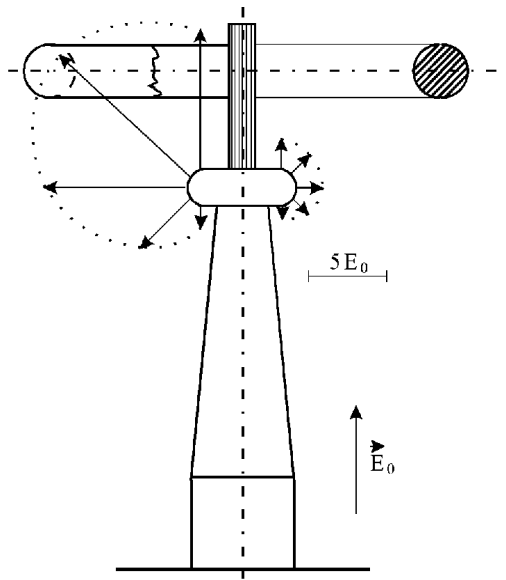

Figure 8. Very significant reduction of the field strength on head and rope end can be achieved by putting a thoroidal electrode coaxially to the head

of the thoroidal protecting electrode (a measuring scale for the field strength is presented in Fig. 8). On the right side of Fig. 8 the polar diagram (also drawn by dotted line) represents the field strengths on the crown of the head in the presence of the protecting electrode defined by parameters

$$R = 0.2 \text{ m}, \quad r = 0.04 \text{ m}, \quad \text{and} \quad z_0 = 0.55 \text{ m}.$$

These parameters provide the lowest maximum field strength on the crown. The largest ratio of the maximum values of the field strengths on the crown of the head without and with the protecting thoroidal electrode is 5.74.

The protecting electrode has an appreciable reducing effect on the tangential component of the field strength on the surface of the rope, too. The two diagrams in Fig. 9 represent the ratio of the tangential component of the field strength along the rope,  $E_r$ , and the impressed field,  $E_0$ , in the two particular cases:

- (a) Without the thoroidal protecting electrode; and
- (b) The protecting electrode is present and its geometry corresponds to the largest protection ratio on the crown of the head (5.74).

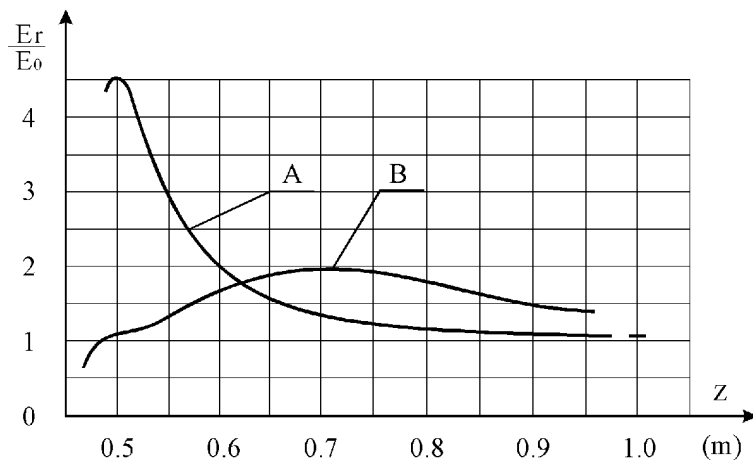

Figure 9. The ratio of the tangential component of the field strength along the rope and the impressed field  $E_0$  in the two particular cases: (A) without the thoroidal protecting electrode (B) in the presence of the protecting electrode the geometry of which corresponds to the largest protection ratio on the crown of the head

## 7. Conclusions

A brief survey of problems connected with the static atmospheric electricity and insulation of guy ropes of MF and LF broadcast mast antennas is given, and some theoretical contributions and technical solutions to these problems are reviewed. Particular emphasis is laid on some contributions which were made by the research team composed of the investigators from the Faculty of Electrical Engineering in Belgrade and Faculty of Electronic Engineering in Niš.

The first contribution refers to an accurate and efficient method for computing the electrostatic fields in the surroundings of the stayed antenna masts and the electric voltages across the stay insulators (Reference [4]). This method represents a valuable means to learn quantitatively the above mentioned phenomena connected with the static atmospheric electricity.

A further advance in the matter is the method for eliminating the static electricity from the stays, which has been successfully applied to the stayed anti-fading antenna (235m high) of the main MF transmitter of Radio Belgrade (2000kW) (References [9,10]). The method consists in using static drain coils which are connected in parallel to the stay insulators so that they



form anti-resonant circuits with them at the operating frequency ( $684kHz$ ).

The third contribution is novel approach to the design of the insulators in MF tower broadcast antenna stays. After static discharges on stay insulators are efficiently eliminated by the use of static drain coils, only relatively small RF voltages are left on the insulators, so that smaller and cheaper insulators can be used. A new method for the evaluation of these RF voltages is developed and used for the design of the insulators. The new method was first applied in the design of the new MF antenna of Radio Podgorica (Ref. [11] ).

A further contribution in the field is a new MF quarter-wavelength monopole antenna, supported by non insulated stay ropes. The vertical and horizontal radiation patterns of such an antenna are very close to those of a usual quarter-wavelength monopole. Due to the lack of expensive and bulky stay rope insulators, such an antenna is very suitable for extremely large powers. The new antenna system has been adopted as the stand-by antenna for the main MF transmitter of Radio Belgrade (Ref. [13] ).

Finally, an efficient solution for protecting the ends of the synthetic-fibre stay ropes against strong electric fields is developed (Ref. [15] ). The solution consists in adding a toroidal protecting electrode coaxial to the metallic head terminating the rope. An exhaustive theoretical analysis, by using charge simulation method, was performed.

#### REFERENCES

1. G. SIMPSON, F.J. SCRASE: *The distribution of electricity in thunderclouds.* Proc. of the Royal Society, London, Series A, 161, No. 906, p.309, 1937.
2. G.H. BROWN: *A consideration of the radio frequency voltages encountered by the insulating material of broadcast tower antennae.* Proc. IRE, Vol.27, pp. 566-78, September 1939.
3. P. BRUGER: *Pardunenisolation der Mittelwellen antenne Langenberg des West-deutschen Rundfunks.* Rundfunktechn. Mitt., 13, pp. 235-43, May 1969.
4. J.V. SURUTKA, D.M. VELIČKOVIĆ: *Static voltages on the guy insulators of MF and LF broadcast tower antennas.* The Radio and Electronic Engineer, Vol. 43, No. 12, pp. 744-50, December 1973.
5. J. BRADAČ: *Eine mit Pardunen ohne Isolationverankerte Sendeantenne.* Rundfunktechn. Mitt., 24, H. 5, pp. 212-16, 1980.
6. D.M. VELIČKOVIĆ: *A new method for evaluation of HF voltages on the guy insulators of MF and LF broadcast mast antennas.* Ph. D. dissertation, Faculty of Electronic Engineering, University of Nish, (in Serbian).
7. P. BRUGER, B. WANIEWSKI: *Pardunenisolation von MW- and LW-Antennen.* Rundfunktechn. Mitt., 22, H. 4, pp. 172-78, 1978.

8. S. LACHARNAY: *Antenne de radiodiffusion o.k. protegee contre les charges statiques.* Revue Technique de Radiodiffusion et de Television, no. 36, pp. 25-30, 1975.
9. J.V. SURUTKA: *New experiences in eliminating static electricity from guys of high-power MF antennas.* Tehnika-Elektrotehnika, XXVIII, No.10, pp. 1-5, 1979. (in Serbian).
10. J.V. SURUTKA D.M. VELIČKOVIĆ: *The elimination of static discharges on the stays of high-power MF antennas.* EBU Review-Technical, No.208, December 1984.
11. J.V. SURUTKA, A.R. DJORDJEVIĆ: *A novel approach to the design of insulators in MF tower broadcast antenna stays.* Jour. IERE, Vol. 58, No. 1, pp. 33-36, 1988.
12. A.R. DJORDJEVIĆ, B.D. POPOVIĆ, M.B. DRAGOVIĆ: *A method for rapid analysis of wire-antenna structures.* Archiv fur Electrotechnik, Vol. 61, pp. 17-23, 1979.
13. J.V. SURUTKA, A.R. DJORDJEVIĆ: *Elimination of the static atmospheric electricity from the guys of MW and LW broadcast tower antennas.* Bulletin LXXXIX de l'Academie serbe des sciences et des arts, Classe des sciences techniques, No. 22, pp. 13-24, 1985.
14. L. GREGORAČ: *Eine Analyse der Gegebenheiten bei der Verwendung von Kunststoffseilen zum Abspannen von Masten.* Rundfunktechn. Mitt., 25, H. 5, pp. 201-212, 1981.
15. J.V. SURUTKA, S.A. MARKOVIĆ: *The protection of the synthetic-fibre stay ropes against strong electric fields.* Proceedings of the XXIX Yugoslav Conference of ETAN, Nish, June 1985, Vol.V, pp. 115-122.