

## WATER SUPPLY SYSTEM MANAGEMENT IN PRESENCE OF MAJOR DISTURBANCES

UDC 681.5.01 628.29

**Danijela S. Stajić<sup>1</sup>, Marko M. Milošević<sup>2</sup>, Miloš D. Milošević<sup>2</sup>**

<sup>1</sup>Secondary school of electrical engineering "Nikola Tesla", Niš, Serbia

<sup>2</sup>Research and Development Center "Alfatec", Niš, Serbia

**Abstract.** *Water supply system frequently encounters disturbances which lead to operational instability of certain parts of the system, frequent malfunctions and poor energy efficiency. Operational instability is hard to control fully, but it is possible to apply certain solutions for increasing operational efficiency. Automation of pumping stations and reservoirs is introduced to one part of water supplying network. New software is applied, for the case of major disturbances in the system. Operation of the system, automated in this manner, is explained at the end.*

**Key words:** *water supply systems, operational instability, management, control*

### 1. INTRODUCTION

Water supply systems are very important parts of the infrastructure, and thus their stable operation is of the greatest importance for normal living, both in large cities as well as in the less developed areas. In order to achieve the primary task of these systems, which is reliable water supply for all of the residents of a certain territory, using different control algorithms and modern techniques for communication with remote parts of the network, operational efficiency can be significantly increased. Water supply system control is basically the maintaining of the desired water pressure in the system with avoiding large fluctuations, for which it is necessary to make a proper selection of pumps, reservoirs and regulation regime. Water supply systems require reliable operation of pumps as well as adjustment of the pumps capacity to water consumption in every moment. Reliable operation of the pumps may be achieved by monitoring all relevant electrical parameters such as supply phase voltages and currents, supply frequency, pump motor temperature, system pressure, water flow through pump, required energy for transport of the water. Reducing energy consumption in water supply systems can be achieved by coordination between nominal power of the pump and

---

Received September 24, 2012

Corresponding author: Danijela S. Stajić

Secondary school of electrical engineering "Nikola Tesla", Aleksandra Medvedeva 18, 18000, Niš, Serbia

E-mail: danijelastajic@yahoo.com

water consumption, meaning the pump is operating with its full capacity. Sometimes, although the proper selection of the pumps has been made and all of the necessary calculations have been performed, problems arise which can not be foreseen like: reservoir discharge, pipeline rupture, reservoir overflow, breakdown of communication between pump station and reservoir and many others. These problems can not be entirely prevented, but certain control approach can be applied, resulting in rapid response in case of emergency. This paper analyzes the part of a water supply system with embedded system of centralized control of pump station from a single command and control center. Having detailed information on the operation of pumps and their related equipment, this technical solution can be used as a back-up protection system, reducing the number of failures to a minimum. An additional advantage of this system lays in the fact that in case of malfunction of any element which endangers normal operation of a pump station the information is immediately transferred to command and control center or to a pump station operator. Besides the description of the centralized control system, this paper also presents results of its application in certain pump stations and in related reservoir through different emergency situations causing major disturbances in its operation.

## 2. MATHEMATICAL MODEL OF WATER SUPPLY SYSTEM

This paper presents an analysis of the part of water supply network encompassing three pump stations, pumping water into reservoirs in different height zones (Figure 1).

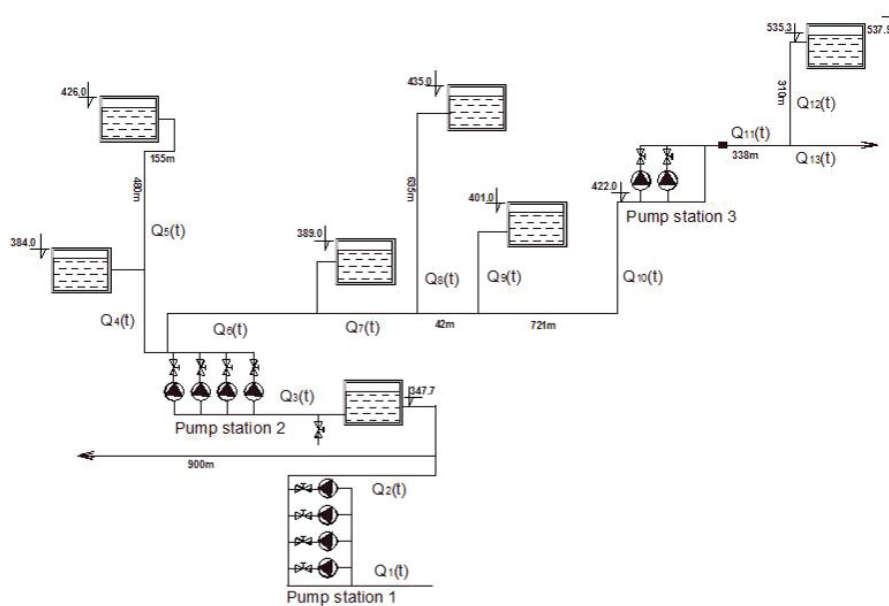

**Fig. 1.** Schematic overview of a part of the water supply system

According to Figure 1, mathematical model of water supply system can be described by three groups of equations:

- Differential equations describing dynamics of the reservoir.
- Differential equations describing pipelines.
- Algebraic equations describing pumps operation.

Following stands for the  $i$ -th reservoir [7-8]

$$\rho A_i \frac{d(\Delta h_i(t))}{dt} + \frac{Q_{iN}}{2h_N} \Delta h_i(t) = \frac{Q_{iN}}{h_N} Q_{i-1}(t), i = 1, \dots, n. \quad (1)$$

Respectively:

$$C \frac{d(\Delta h_i(t))}{dt} + \frac{1}{R_v} \Delta h_i(t) = \frac{Q_{iN}}{h_N} Q_{i-1}(t), i = 1, \dots, n. \quad (2)$$

where

$$R_v = \frac{2h_N}{Q_{iN}} \text{ and } C = \rho A_i.$$

Following stands for water supply pipelines

$$Q_i(t) = Q_{i-1}(t - \tau_i) \quad (3)$$

where  $\tau_i = \frac{l_i}{v_i}$  is proper delay in  $i$ -th pipeline.

Following equation for pump strain as a function of flow stands for pumps

$$H_i(Q_i) = \sum_{j=0}^k H_j Q_i^j \quad (4)$$

Bernoulli's equation stands in case of free method.

$$Q_i(t) = K v \rho \sqrt{\Delta p(t)} = K_i \sqrt{\rho^2 h_i(t)} \quad (5)$$

Using the standard method for identification, according to direct measurements of electrical parameters and taking into account information on pumps given in the manufacturer's catalogues, the identification of standard parameters has been made [9]. Operating characteristic obtained for pumping unit is given in Figure 2.

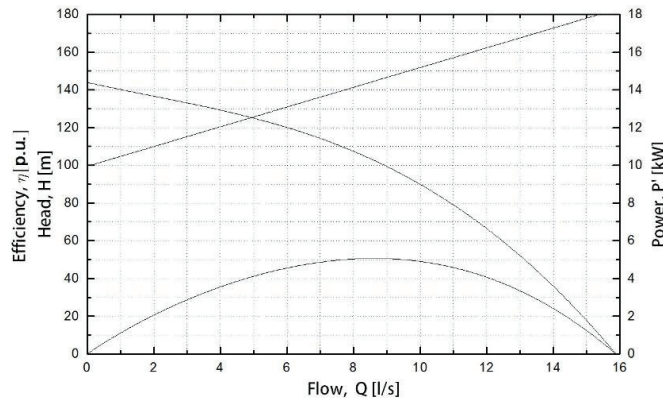

**Fig. 2.** Operating characteristic for pumping unit in Pump station 3

#### 4. BEHAVIOR OF SYSTEM IN PRESENCE OF MAJOR DISTURBANCES

Since installment of the pump station control system to this day, operation of the pump station has become significantly more stable, especially in the sense of overcoming problems which previously demanded long time for solving. This results in the decrease of losses in this part of water supply system.

Beside its main purpose, which is monitoring and control, this system works as a backup protection system, providing following functionalities:

- 1. Maintain the water level in the reservoir within the given boundaries.** The main task is to regulate the water level in the reservoir. According to the water level and the immersion of the probe in the reservoir, the comparison with predefined boundaries is made, after which the system sets a command for switching on or turning off of pumping unit. Pump station 3 has two pumping units and they are operating cyclically. Therefore, one of the pumping units works as a backup unit in every moment, which is beneficial for the operating life time of each of pumping units.
- 2. Protection from water overflowing from the reservoir.** In case of any kind of malfunction of upper boundary probe and increase of the water level in the reservoir beyond this upper boundary, the system identifies immersion of overflowing probe, issues a signal for turning the operating pumping unit off and informs competent command and control center.
- 3. Protection from discharging of the reservoir.** In case of sudden decrease of the water level in the reservoir, under the lower boundary probe level, the system issues a command for switching pumping units on and informs the competent command and control center about the current situation. The system is also able to predict the possibility of failure of pumping units, in which case it informs competent command and control center or system operator.
- 4. Protection from breakdown in communication with the reservoir.** Discharging of the reservoir may occur as a result of breakdown in communication between Pump station 3 and reservoir. If pumping units are operating at the moment of loss of communication, the signal for turning off will not be received, and unnecessary pumping of great amount of water will take place. If pumping units were turned off at the moment of loss of communication, the signal for switching on will not be received, so the reservoir may be fully discharged. In order to prevent this kind of problems, a part of the system software records data on maximal and minimal operation time of pumping units, depending on time of the day and month of the year, as well as on maximal duration of time interval between two switching on of the pumping units. First time pumping units operation lasts longer than maximal operational interval, the signal for turning off of pumping units is sent. After the time interval equal to longest recorded interval between two switching on has expired, pumping units are cyclically switched on and turned off, according to average operational time and average interval between two switching on for time of the day and for the month. An example of switching on and operation of the pumping units after discharging of the reservoir is presented in Figure 3.

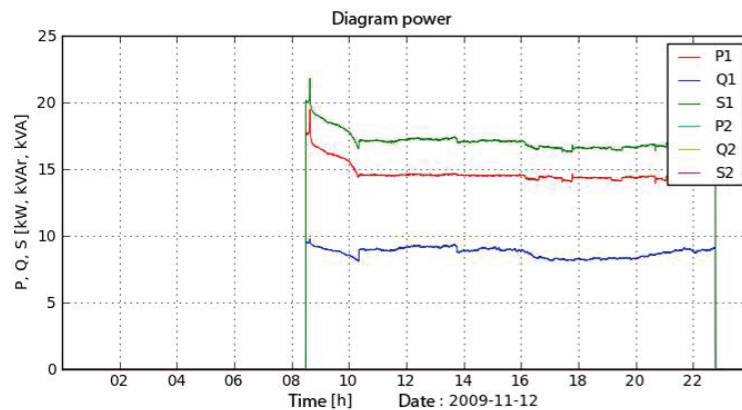

**Fig. 3.** Switching on and operation of the pumping units after discharging of the reservoir

- 5. Protection from unnecessary switching on or turning off of pumping units.** In water supply systems there is often seen alternating sudden rise and fall of pressure in water supply pipes. When pumping units are considered, this is manifested by frequent switching on and turning off, which leads to malfunctions in the system. The system is able to recognize great deviations and distortions in electrical parameters of pumping units, it then detects described problem and issues the signal for turning off of the pumping units. An example of operation of the pumping units with unnecessary switching on or turning off is presented in Figure 4.

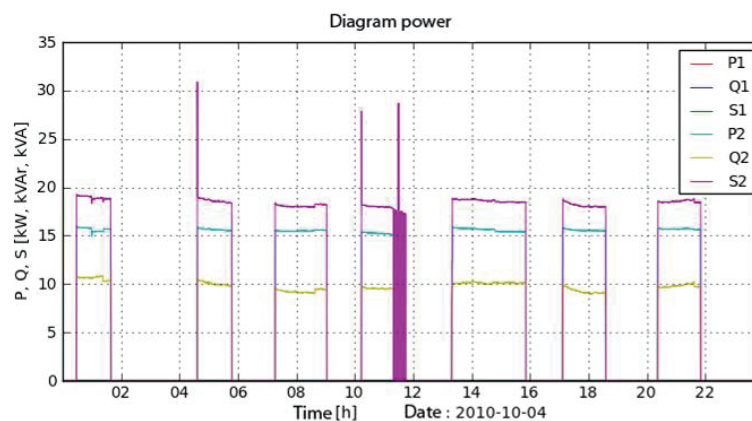

**Fig. 4.** Operation of the pumping units with unnecessary switching on or turning off

- 6. Protection from dry run of pumping units.** Dry run is a consequence of disappearance of the fluid in pump impeller. In that case power whose electric motor drive is receiving from power network is significantly smaller than minimal power in case of the immersed pump impeller. In this situation, protection system issues a signal for turning off of the pumping unit. An example of dry run of the pumping unit is presented in Figure 5.

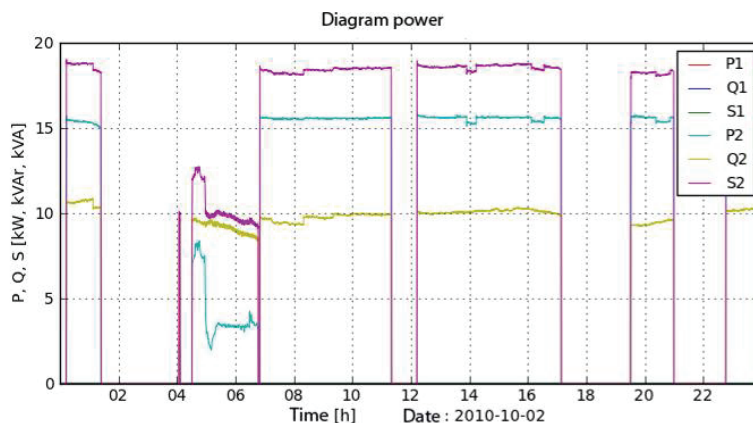

**Fig. 5.** Dry run of the pumping unit

#### 4. DESCRIPTION OF A CENTRALIZED CONTROL OF A WATER SUPPLY SYSTEM

The basic function of this system is to provide continuous monitoring of the water level in the reservoir, by which is fulfilled mandatory requirement for control of all of events occurring in pump station without operator's surveillance.

System operates in the way that monitoring and control are performed through several levels:

1. Level of sensors,
2. Level of execution of software modules,
3. Level of server,
4. Level of SCADA application.

Level of sensors includes devices participating in gathering information on the situation on the ground. The most commonly used devices on this level are ones communicating via MODBUS protocol, like temperature sensors, panel network analyzers, telemetry modules (TMOD), command and control modules (CCM).

On the level of execution of software modules, certain programs are started, with an aim to send appropriate signals and indirectly affect the state of the system, according to information gathered from sensors and according to predefined requests.

The level of server is used for storage of all of relevant information in the system. Access to information from external environment is possible only through the server. Information from the server are distributed through multi-communication infrastructure, which supports a great number of communication channels (Ethernet, GSM/GPRS, digital radio modems, wireless networks and other).

Monitoring is performed from command and control center through SCADA application, which provides insight into all of the elements of the system, as well as into current state of the system and chronology of events.

Functional scheme of the system is shown in Figure 6.

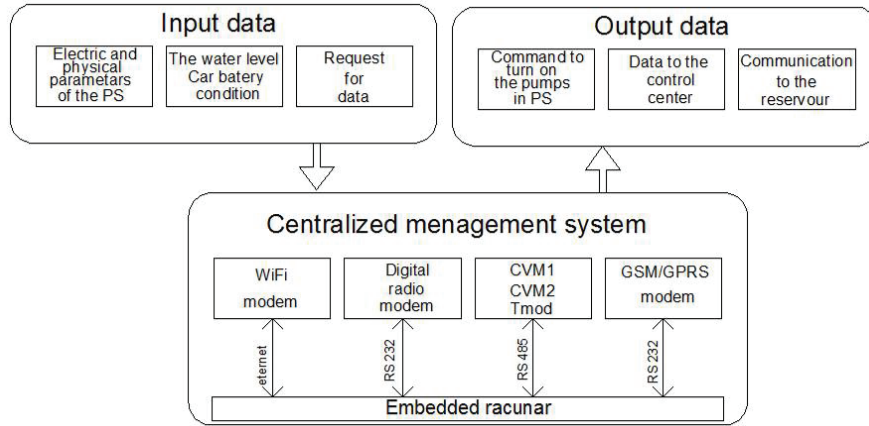

**Fig. 6.** Functional scheme of the system of centralized control

Input data are all of the electrical parameters, obtained from Pump station 3, and they are related to their pumping units: phase and line voltages on the bus bars of the electric facility, frequency, line currents of pump motor loads, active, reactive and apparent powers of pump motor loads per phase, THD (Total Harmonic Distortion factor) of currents and voltages, current and voltage asymmetry and power factors. External and internal temperatures are measured as well. Information from the sensor of movement in the Pump station 3 and from the sensor of door is recorded too.

Input data from reservoir are the water level, determined according to information from submerged probes, energy level of battery and charging of battery from solar panels.

According to the gathered data, after their processing, command signals are generated, for switching on and turning off of the pumping units, or messages are generated and transferred to command and control center or to pump station operator.

Figure 7 presents operational characteristics obtained after the installation of this control system and they show that water supply system operates correctly even in the presence of major disturbances.

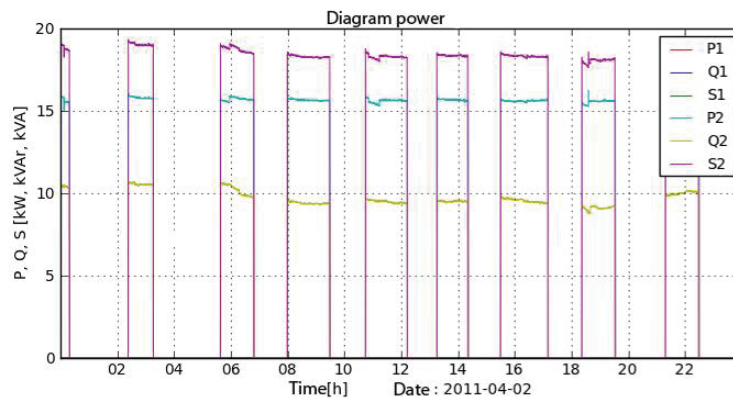

**Fig. 7.** Operational characteristics of pumping units in nominal operational regime

## 5. CONCLUSION

This paper presents one particular method of control of a large urban water supply system. Major disturbances in the system, causing instability of a part of the water supply system, are assumed. Although elements of the system are relatively simple (reservoir, pipelines, pumping units), complex configuration of the system and large number of these elements may lead to instability or outages of supply in the system. The installation of the new control system resulted in great improvements in operation which eliminated outages of water supply as well as oscillations in its operation. Measurements performed in automated part of the water supply system show its normal operation during a long period of time in presence of major disturbances.

Further improvements of regulation in automated system may lead to even greater reduction of water level oscillations in reservoirs in presence of major disturbances or in case of fallouts of parts of the system from normal operation.

## REFERENCES

1. E. Lindell, K. Ormsbee, E. Lansey, "Optimal control of water supply pumping systems", J. Water Resour. Plann. Manage, vol. 120, no. 2, 1994.
2. E. Stancel, I. Stoian, I. Kovacs, B. Z. Gyurka, Sz. Balogh, "Urban water supply distributed control system", IEEE International Conference on Automation, Quality and Testing, Robotics, AQTR 2008, 22-25. May, pp. 316-320.
3. Z. Stajić, Z. Golubović, Lj. Vučković, "Measuring information system for pumping stations in terms of preventive engineering", Energy Technology, No. 1-2, pp.48-51, 2000.
4. Z. P. Stajić, V. Milenković, "Measuring information system for the pump station control in the function of preventive engineering", Facta Universitatis Series: Working and Living Environmental Protection, vol. 3, no. 1, pp. 73-81, 2006.
5. Z. Stajić, M. Radić, "An example of extreme increase of pump station's energy efficiency" Communications in Dependability and Quality Management, vol. 8, no. 2, pp. 45-50, 2008.
6. M. Radić, D. Nikolić, Z. P. Stajić, Đ. R. Vukić, "A practical example of the power efficiency of small pump station redesign", Agricultural Engineering, no. 2, pp.43-52, 2005.
7. D. Debeljković, A. Sićović, G. Simeunović, V. Mulić, "Mathematical models of objects and processes in automatic control systems", Faculty of Mechanical Engineering, Belgrade, 2006.
8. D. Debeljković, G. Simeunović, A. Sićović, "Dynamics of structures and processes in automatic control systems", Faculty of Mechanical Engineering, Belgrade, 2009.
9. B. Danković, D. Antić, Z. Jovanović, "Upravljanje procesima", Faculty of Electronic Engineering, Nis, 2010, (in Serbian).

## UPRAVLJANJE SISTEMOM ZA VODOSNABDEVANJE U PRISUSTVU VELIKIH POREMEĆAJA

**Danijela S. Stajić, Marko M. Milošević, Miloš D. Milošević**

*U sistemima vodosnabdevanja često dolazi do poremećaja koji prouzrokuju nestabilan rad delova sistema, česte kvarove i lošu energetska efikasnost. Nestabilnost rada ovako velikih sistema teško je u potpunosti kontrolisati, ali se mogu primeniti određena rešenja koja povećavaju efikasnost rada. Na delu mreže vodosnabdevanja izvršena je automatizacija rada pumpnih stanica i rezervoara. Primenjen je novi softver za slučaj velikih poremećaja u sistemu. Na kraju je prikazan rad ovako automatizovanog sistema sa novim algoritmom upravljanja.*

*Ključne reči: sistemi vodosnabdevanja, nestabilan rad, upravljanje*